

# INOX PREMIER HIGH FLOW FILTER HOUSING

## PFH-SGB-4HF-40-4F-GP-ML

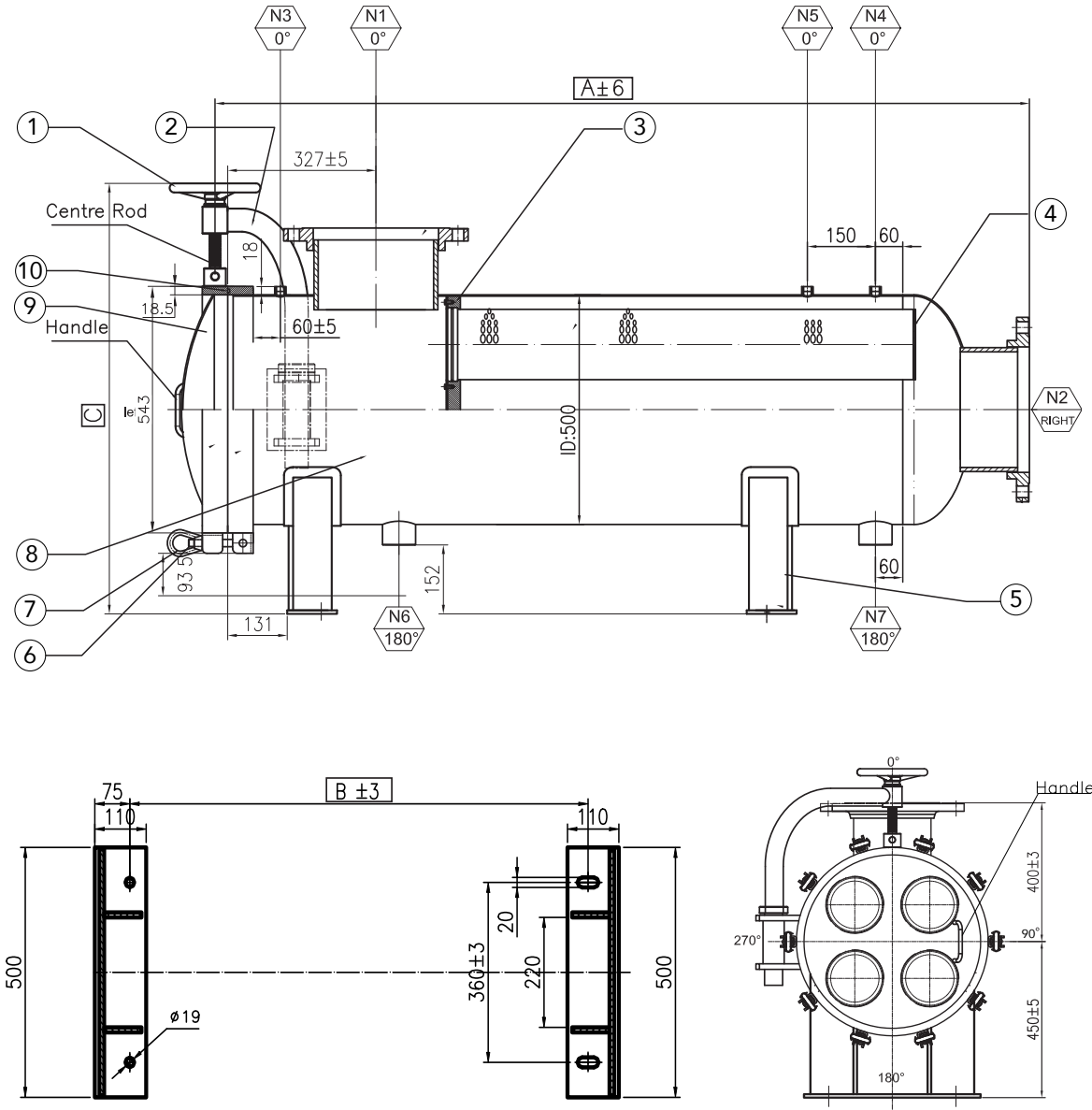

Overall Dimensions			
To Accommodate Filter Qty x Length	A mm	B mm	C mm
4 x 40"	1795	980	948

Port Details					
No.	Type	Size	No.	Type	Size
N1	Inlet	DN100 PN16 (4" Flange)	N4	Vent	1/2" BSPT-F
N2	Outlet	DN100 PN16 (4" Flange)	N5	Gauge	1/2" BSPT-F
N3	Gauge	1/2" BSPT-F	N6	Drain (x2)	2" BSPT-F

Components					
No.	Name	Material	No.	Name	Material
1	Davit Wheel	304	6	Nut (x10)	A351M EF8 Steel
2	Davit Arm	304	7	Eye Bolt (x10)	A193 B7 Steel
3	Plate	316L	8	Body	316L
4	Filter Support Basket (x4)	316L	9	Lid	316L
5	Legs	304	10	O-Ring	BUNA-N

Technical Information	Maximum Operating Temperature	120°C
	Design Pressure	7 bar
	Hydrostatic Test Pressure	10 bar

- Bolt holes in nozzle flanges shall straddle major axis of the vessel
- Pressure relief device should be installed on the outer piping by the customer to assure that pressure in the vessel can not exceed the design pressure indicated
- All dimensions are approximate in mm